



# Rocky Mountain Snow Guards Inc

ROCKY MOUNTAIN SNOW GUARDS  
4231 S NATCHES CT., UNIT C  
ENGLEWOOD, CO 80110  
PHONE: (720) 379-7756  
FAX: (720) 387-8361  
[www.rockymountainsnowguards.com](http://www.rockymountainsnowguards.com)

## S-5® ColorGard SNOW BAR SYSTEM

### AVAILABLE MATERIALS:

- ALUMINUM
- BRASS (S-5® B-CLAMP ONLY)

### INFORMATION:

- 7'8" Punched or Unpunched bar  
Clamps to fit all seam profiles  
Specific load ratings for all panels  
Excellent Choice for:
  - Standing seam metal panel roofs
  - Through-fastened metal panels (Versabracke)
  - Corrugated metal panels (Corrubracke)

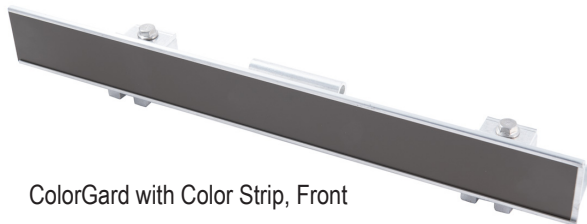

ColorGard with Color Strip, Front



Unpunched ColorGard Bar with S Clamps, Veracips  
and SnoClip II, Rear



Punched ColorGard Bar with S Clamps, Rear

### EXAMPLES:



# S-5!<sup>®</sup>

## The Right Way!<sup>®</sup>

### S-5-K Grip Snow Clamp

The S-5-K Grip Snow clamp was specifically developed to fit Klip-Rib<sup>®</sup> and other bulb snap-together seams. The design utilizes multiple inserts (sold separately) in order to accommodate a variety of bulb snap-together profiles. Each insert has a unique shape that allows for a tight fit and provides increased holding strength over other attachment options. This product is designed and tested to work with ColorGard<sup>®</sup>.

The S-5-K Grip Snow also eliminates the large moment arm other clamps use for these profiles. Instead, it features a low mounting surface area, with the mounting bolt directly over the center of the seam. This dramatically increases the strength of the clamp, making it perfect for use with heavy-duty applications.

The head of the flanged bolts control the amount of compression, which reduces the possibility of over-compressing the seam, and makes installation a snap!

Just place the clamp on the seam, position the insert piece, and tighten the flanged bolts at the base. Then, affix ancillary items using the top bolt provided. Go to: [www.S-5.com/tools](http://www.S-5.com/tools) for information about properly attaching S-5!<sup>®</sup> clamps.

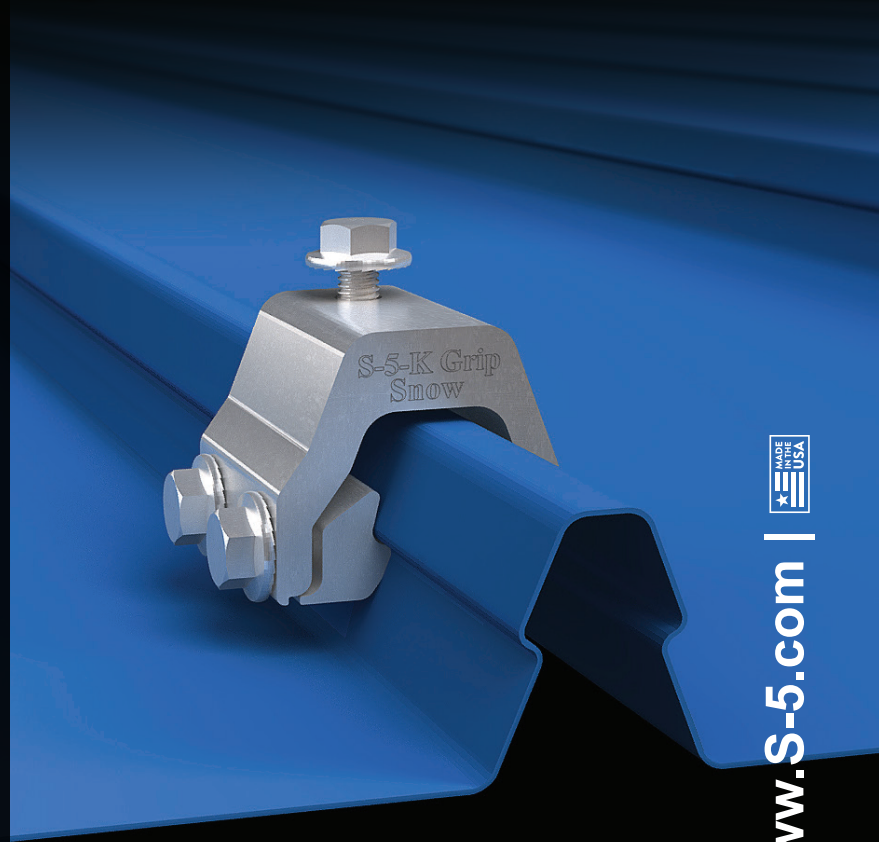

The S-5-K Grip Snow was specifically developed to attach ColorGard<sup>®</sup> snow retention system to Klip-Rib<sup>®</sup> and other bulb snap-together seams.

The right way to attach almost anything to metal roofs!

S-5-K Grip Snow



888-825-3432 | [www.S-5.com](http://www.S-5.com) |

The S-5-K Grip Snow eliminates the large moment arm and features a low mounting surface area with the mounting bolt directly over the center of the seam, which dramatically increases the strength of the clamp.

The S-5-K Grip Snow clamp is furnished with the hardware shown to the right. The clamp is provided with an M8-1.25 X 16.00 mm Hex Flange Bolt. A structural aluminum attachment clamp, the S-5-K Grip Snow is compatible with most common metal roofing materials excluding copper and is designed to accommodate the S-5!<sup>®</sup> ColorGard<sup>®</sup> snow retention system. All included hardware is stainless steel. Please visit [www.S-5.com](http://www.S-5.com) for more information including CAD details, metallurgical compatibilities, and specifications.

The S-5-K Grip Snow clamp has been tested for load-to-failure results on a variety of standing seam roof profiles from leading panel manufacturers. When placed near a clip location, the S-5-K Grip Snow achieves unsurpassed holding strength, dramatically reducing the need for multiple rows of snow retention in regions with heavy snow loads. The independent lab test reports found on our website at [www.S-5.com](http://www.S-5.com) prove that S-5!<sup>®</sup> holding strength is unmatched in the industry.

An S-5-K Grip clamp compatible with an M10-1.5 X 16.00 mm Hex Flange Bolt is available upon request for an additional up charge.

## Example Profile

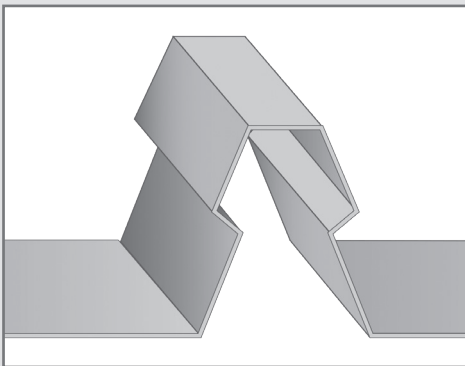

## S-5-K Grip Snow

(With S-5-GX 10 Insert)

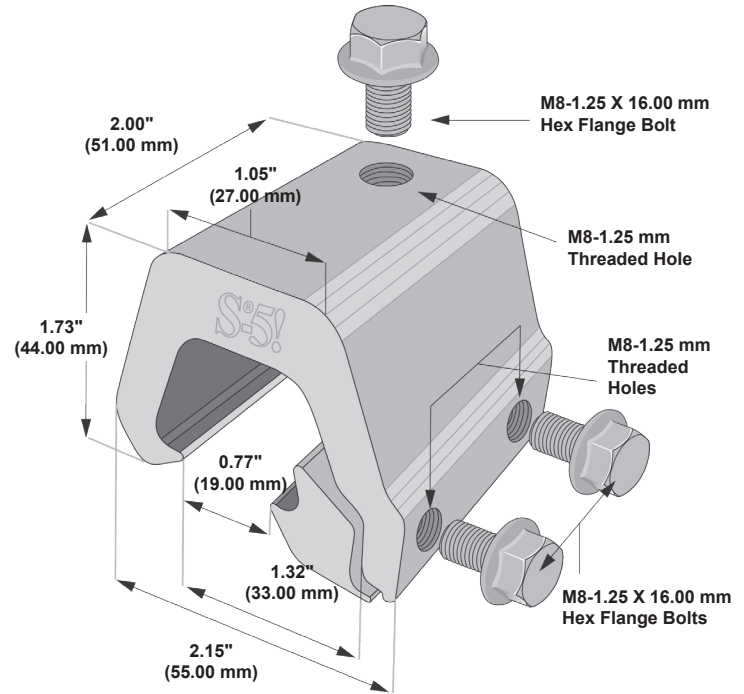

## Insert Options

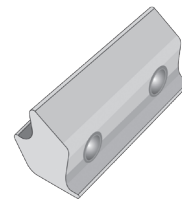

S-5-GX 10 Insert

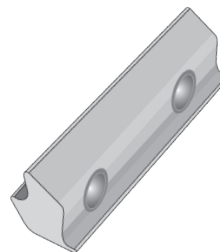

S-5-GX 50 Insert

## Profiles

### S-5-GX 10

- LYSAGHT KLIP-LOK<sup>®</sup> 406
- McElroy Metal Mirage
- AEP Span Klip-Rib<sup>®</sup>
- Metal Sales Clip-Loc
- SpeedDeck<sup>®</sup> SpeedDeck<sup>®</sup>
- Safintra Saflok 410
- Safintra Saflok 700
- And other similar profiles

### S-5-GX 50

- LYSAGHT KLIP-LOK Classic<sup>®</sup> 700
- LYSAGHT KLIP-LOK 700 Hi-Strength<sup>®</sup>
- Stramit Speed Deck Ultra<sup>®</sup>
- Fielders KingKlip<sup>®</sup> 700
- And other similar profiles

If you have a profile not listed here, please contact S-5! to request a sample for testing.

### S-5!<sup>®</sup> Warning! Please use this product responsibly!

Products are protected by multiple U.S. and foreign patents. For published data regarding holding strength, fastener torque, patents, and trademarks, visit the S-5! website at [www.S-5.com](http://www.S-5.com).

Copyright 2021, Metal Roof Innovations, Ltd.

S-5! aggressively protects its patents, trademarks, and copyrights. Version 081321.

Distributed by

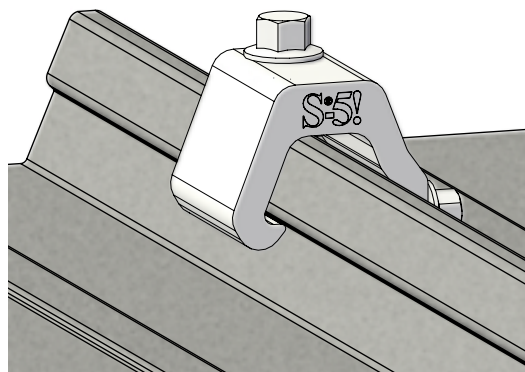

# S-5-K SNOW GRIP

## S-5-GX 10 (INSERT)

M8-1.25 THREADED HOLE

TOP

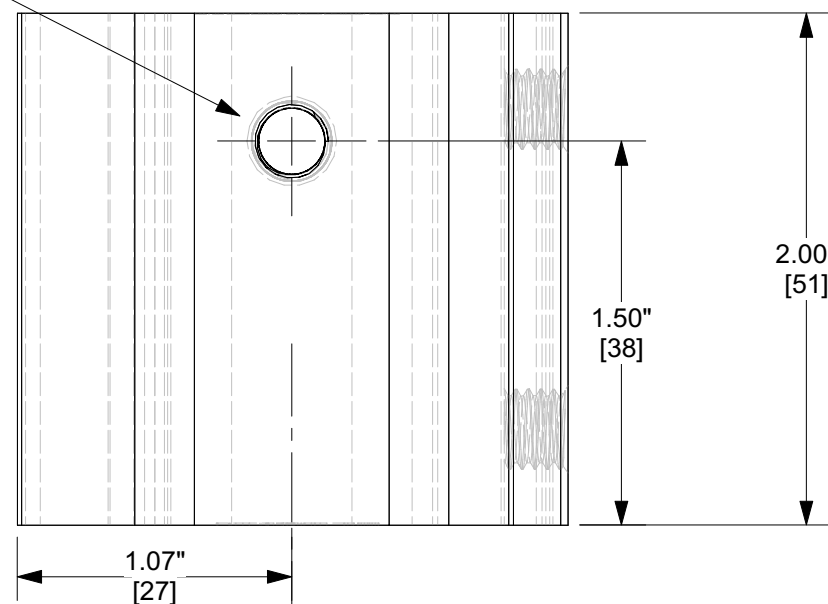

1.73" [44]

1.05" [27]

.77" [19]

1.32" [33]

2.15" [55]

SCALE: 2X

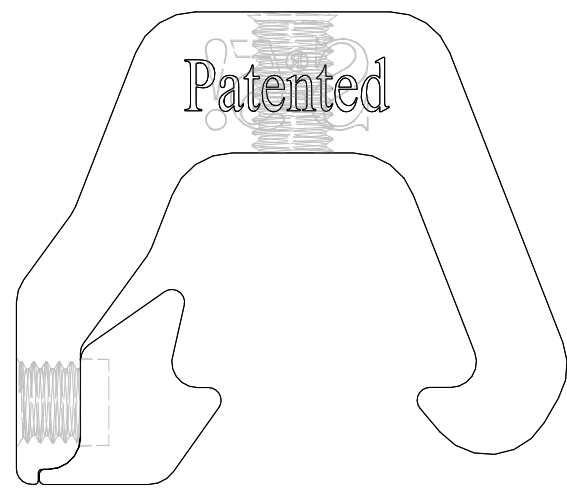

BACK

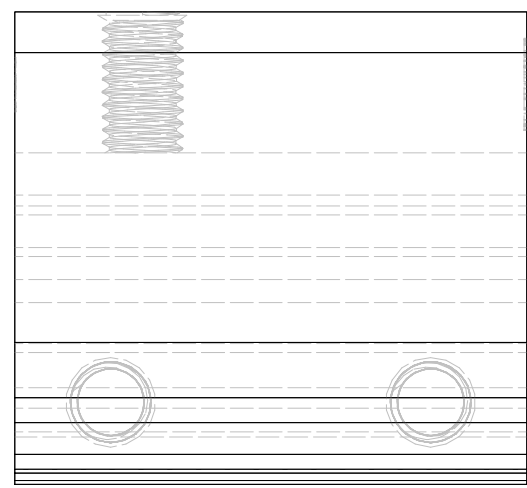

LEFT

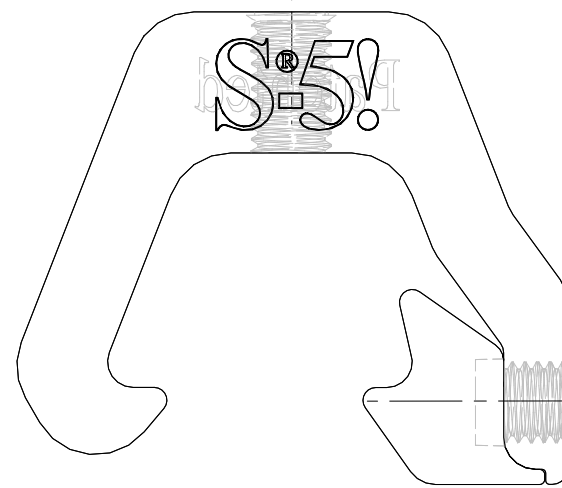

FRONT

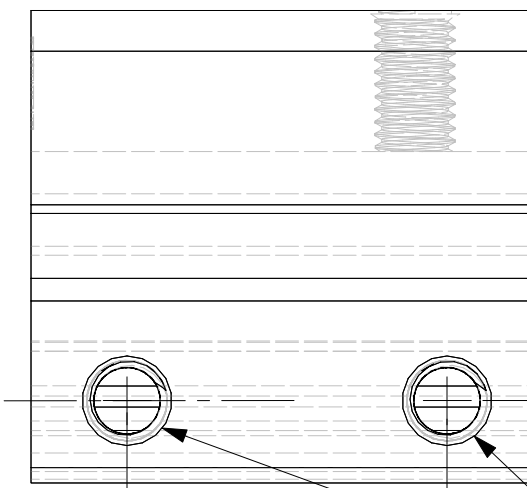

RIGHT

(2X) M8-1.25 THREADED HOLE

**General Notes**

1. S-5-K GRIP SNOW
2. S-5-GX10 INSERT
3. M8-1.25 16 mm LENGTH 13 mm HEX FLANGE BOLT
4. EXAMPLE ROOF PROFILE

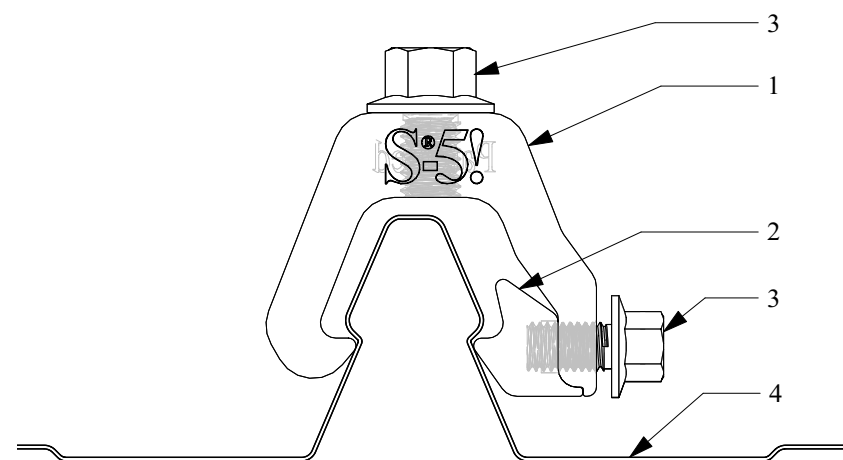

**FOR STANDING SEAM SPECIFIC MECHANICAL LOAD TEST INFORMATION AND CLAMP INSTALLATION INFORMATION PLEASE VISIT: WWW.S-5.COM**

MATERIAL: <b>6000 SERIES AL</b>	 <p><b>S-5!</b> The Right Way!</p>	METAL ROOF INNOVATIONS, LTD. 8655 TABLE BUTTE RD COLORADO SPRINGS, CO 80908 719-495-0518 719-495-0045 (FAX)	
EST ASSEMBLY WEIGHT :			
SUPPLIED HARDWARE: <small>(3) M8-1.25 X 16MM (13MM HEX) 18/8 SS</small>	TITLE S-5-K GRIP WITH GX 10 INSERT		
SCALE: <b>1:0.75</b>	DRAWING NO. KG47-A 2013	DRAWN BY MS	DATE 02/15/2013
OTHER:	<small>S-5!® PRODUCTS ARE PROTECTED BY MULTIPLE U.S. PATENTS INCLUDING 5,228,248, 5,983,588 AND 6,164,033 (OTHERS ISSUED AND PENDING). EUROPEAN PATENTS ARE ALSO APPLIED FOR AND PENDING UNDER THE PATENT COOPERATION TREATY WITH DIVISIONAL FILING RIGHTS RETAINED. METAL ROOF INNOVATIONS, LTD. (LICENSOR OF S-5!® TECHNOLOGY) AGGRESSIVELY PROSECUTES PATENT INFRINGEMENT.</small>		

## Installation Instructions

**S-5!® Warning!** Please use these products responsibly! Visit our website or contact your S-5! distributor for available load test results. The user and/or installer of these parts is responsible for all necessary engineering and design to ensure the S-5-K Grip Snow has been properly spaced and configured.

**Notice to S-5! product users:** Due to the many variables involved with specific panel products, climates, snow melt phenomena, and job particulars, the manufacturer cannot and does not express any opinions as to the suitability of any S-5! assembly for any specific application and assumes no liability with respect thereto. S-5! products are tested for ultimate holding strength on various profile types and materials. This information is available from the S-5! website: [www.S-5.com](http://www.S-5.com). This document is an installation guide only and the photographs and drawings herein are for the purpose of illustrating installation tools and techniques, not system designs.

**The S-5-K Grip Snow clamp is designed to fit Klip Rib® and other bulb snap-together seams. This product is designed and tested to work with ColorGard® and X-Gard™ snow retention systems.**

The S-5-K Grip Snow utilizes multiple inserts (sold separately) in order to accommodate a variety of bulb snap-together profiles. Each insert has a unique shape that allows for a tight fit and provides increased holding strength over other attachment options.

The appropriate seam profiles for each insert option are listed on the back of these installation instructions.

The heads of the clamp's M8-1.25 X 13 mm Hex Flange Bolts control the amount of compression, which reduces the possibility of over-compressing the seam, and makes installation a snap!

## Tools Needed

- Dial-Calibrated Torque Wrench\*  
(\*For accurate tension values, do NOT use a clicking torque wrench)

## To Install S-5-K Grip Snow

**For use with ColorGard:** If the ColorGard assembly utilizes the VersaClip™ for attachment of the ColorGard crossmember to the clamps, the bolt hole in the clamp should be at the upslope end of the clamp. If the assembly uses punched ColorGard without VersaClip, the hole should be at the downslope end of the clamp.

**For use with X-Gard:** The bolt hole in the clamp should always be at the upslope end of the clamp.

1. Position clamp insert at desired location along the rib, just under the fold of the rib. Clamp placement MUST be located within 2" upslope of concealed clip (not directly over clip locations).
2. Roll the clamp into position over the seam and clamp insert piece. Position the clamp so that it is centered over the clamp insert with approximately 2 mm of insert overhang on each side of the clamp.
3. Partially thread the two bolts into the base of the S-5-K Grip Snow by hand. The bolts should engage the divots in each end of the S-5-K Grip Snow insert.
4. Tighten the bolts at the base of the S-5-K Grip Snow using a ratchet or screw gun with a 13 mm hex. For optimal holding strength, bolts should be tensioned to 20 inch pounds.
5. Secure S-5! ColorGard snow retention system to clamps according to ColorGard installation instructions.

These instructions are for use by those experienced in the trade. Always follow appropriate safety precautions and use appropriate tools.

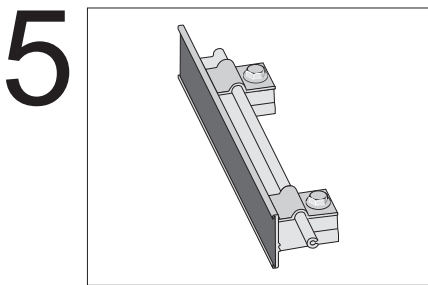
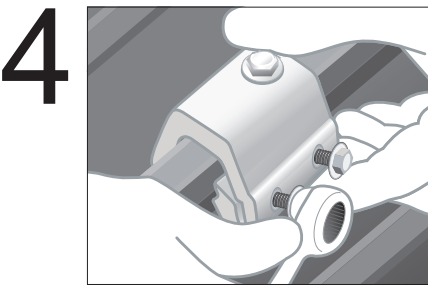
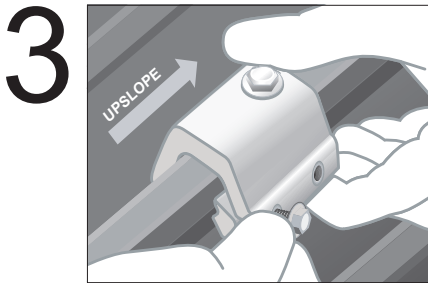
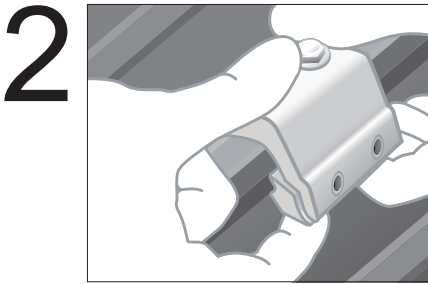
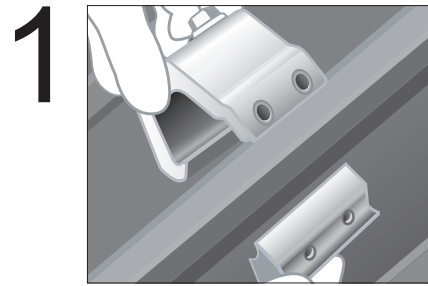

### Seam Profiles

**S-5-K Grip Snow is designed to fit Klip-Rib® and other bulb snap-together seams.**

**Seam profiles for the S-5-GX 10 insert:**

- LYSAGHT KLIP-LOK® 406
- McElroy Metal Mirage
- AEP Span Klip-Rib®
- Metal Sales Clip-Loc
- SpeedDeck® SpeedDeck®
- Safintra Saflok 410
- Safintra Saflok 700
- Domico GBS Domitec® Dach
- And other similar profiles

**Seam profiles for the S-5-GX 50 insert:**

- LYSAGHT KLIP-LOK Classic® 700
- LYSAGHT KLIP-LOK 700 Hi-Strength®
- Stramit Speed Deck Ultra®
- Fielders KingKlip® 700
- And other similar profiles

If you have a profile not listed here, please contact S-5!® to request a sample for testing.

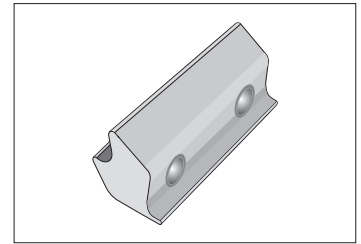

**S-5-GX 10 Insert**

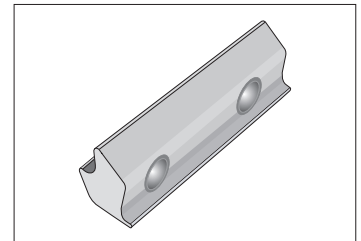

**S-5-GX 50 Insert**

#### **S-5!® Warning! Please use this product responsibly!**

S-5!® Warning! Please use this product responsibly! Products are protected by multiple U.S. and foreign patents. For published data regarding holding strength, fastener torque, patents, and trademarks, visit the S-5! website at [www.S-5.com](http://www.S-5.com).

Copyright 2014, Metal Roof Innovations, Ltd. S-5! products are patent protected.

S-5! aggressively protects its patents, trademarks, and copyrights. Version 102714.

## Installation Instructions

**Stop! Has your ColorGuard<sup>®</sup> system been designed properly with the assistance of a distributor or the online ColorGuard calculator? If not, see our Calculator and Load Table at [www.S-5.com](http://www.S-5.com), or ask your distributor!**

**Notice to S-5!<sup>®</sup> users:** Specific layout and assembly schematics for S-5! products are the responsibility of the user or project designer. Due to the many variables involved with specific panel products, climates, snow melt phenomena, and job particulars, the manufacturer cannot and does not express any opinions as to the suitability of any S-5! assembly for any specific application and assumes no liability with respect thereto. S-5! clamps are tested for ultimate holding strength on various seam types and materials. This information is available from the S-5! website: [www.S-5.com](http://www.S-5.com). This document is an installation guide only and the photographs and drawings herein are for the purpose of illustrating installation tools and techniques, not system designs. Clamp spacing should never exceed 32" with standard products (contact your distributor for products to accommodate a seam spacing greater than 32").

### Tools Needed

- Electric Screw Gun
- Box End Wrench, 1/2" Drive Impact Wrench, or Ratchet
- Saw to cut ColorGuard crossmember
- Tin Snips
- String Line
- Torque Wrench
- Pliers or Vice Grip

### To Install ColorGuard<sup>®</sup>

**1. Before You Start:** First, use a string line across the top of the panel seams at the desired location to establish a true line for installation of the S-5! clamps. Individually measuring from the eave to determine each clamp location is not recommended. **Before continuing, please take a moment to read the important notice about SnoClip<sup>™</sup> on the back side of these installation instructions.**

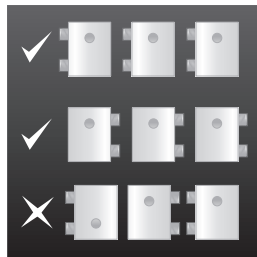
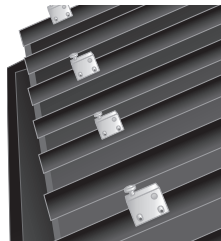

- 2. Preparing The Clamps:** If the ColorGuard assembly utilizes the VersaClip<sup>™</sup> for attachment of the ColorGuard crossmember, the bolt hole in the clamp should be at the upslope end of the clamp. If the assembly uses punched ColorGuard without VersaClip, the hole should be at the downslope end of the clamp. When using the S-5-U, determine which side of the clamp to load the setscrews into, and thread the setscrews into all clamps, being careful that the bolt hole will be in the correct (upslope or downslope) orientation, with the setscrews on the correct side of the seam. Both setscrews must be on the same side of the clamp.
- 3. Installing The Clamps:** S-5! clamps are installed differently depending upon clamp model and seam style. Please see the installation instructions included with your clamps. For maximum holding strength, setscrews should be tensioned and re-tensioned as the seam material

compresses. Screw tension should be verified using a calibrated torque wrench between 160 and 180 inch pounds when used on 22ga steel and between 130 and 150 inch pounds for all other metals and thinner gauges of steel. Please visit our load table at [www.S-5.com](http://www.S-5.com) to determine the proper screw tensions and holding strength.

**Using VersaClip:** When seam spacing is not divisible by 4" (e.g. 12", 16", 24"), or when panels are not laid up true-to-dimension, or when ColorGuard is installed askew to the panel seams (e.g. parallel with the line of a valley), the VersaClip facilitates installation. The VersaClips are inserted into the ColorGuard prior to placement of ColorGuard on the clamps. Align clips with S-5! clamp. VersaClip can be used with punched or unpunched ColorGuard.

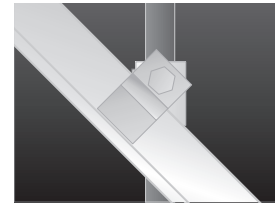

**4. Installing The ColorGuard:**

To maintain color conformity over time, ColorStrips should be sheared from the same pre-finished metal as the roof panels. Shear strips to exactly 2" wide (8' or 10' long). Slide the ColorStrip into the ColorGuard crossmember as shown (right). If the strip length is 8', it may be pre-assembled into the ColorGuard crossmember. If the strip is 10' long, it will be assembled to the ColorGuard as installation progresses. Joints in the ColorGuard should be concealed by offsetting the joints of the ColorStrip from the joints of the ColorGuard. The joints of the ColorStrips can be overlapped about 1/2" if desired. Each ColorStrip should be secured to the ColorGuard somewhere along its length. This is done by pinching the retainer lip of the ColorGuard with an ordinary pair of pliers. It can be done at one end of the ColorGuard section or anywhere along its length to prevent lateral migration of the ColorStrip.

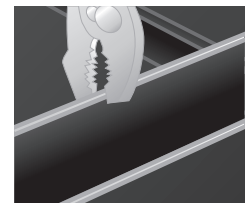
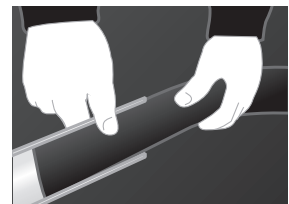

**5. Bolt ColorGard® to Clamps:**

Attach ColorGard to clamps with the stainless bolts and washers provided. Bolts can be tightened with a 9/16" (17 mm) box-end wrench, or ratchet. On larger jobs, a 1/2" drive electric impact will expedite this work. Tension bolts to a minimum of 20 ft. lbs. (27 Nm). Add Splice pieces at each ColorGard joint as shown below. The "dimple" in the Splice piece will automatically provide a 1/8" space between adjoining sections to allow for linear thermal expansion of the ColorGard. Trim ColorGard at the end of the assembly, being sure it does not cantilever more than 4" beyond the last clamp of an assembly. Any trimmed piece of ColorGard must be attached with at least two clamps.

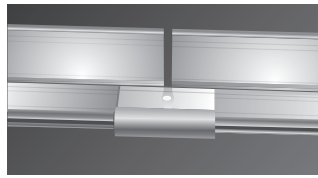
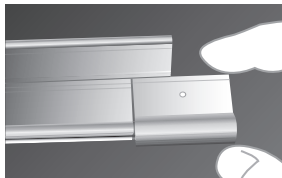
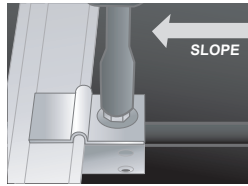

**ColorGard Cutting Tip:** If it is necessary to field cut ColorGard, such as at the end of an assembly, it can be done with a hack saw or electric reciprocating saw with a fine-tooth metal cutting blade. A power mitre saw with a fine tooth carbide tip blade also works well.

**Using VersaBracket™**

1. Install the bracket. See installation instructions that were included with your bracket.
2. Fasten unpunched ColorGard to the top flange of the bracket using a 1/4 - 14 self-drilling screw.



**Using CorruBracket™**

1. Install the bracket. See installation instructions that were included with your bracket.
2. Fasten ColorGard to the bracket in the same fashion as step 5.

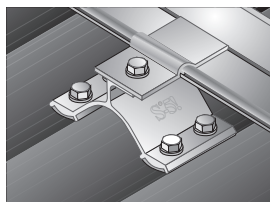

**S-5!® Warning! Please use this product responsibly!**

Products are protected by multiple U.S. and foreign patents. Visit the website at [www.S-5.com](http://www.S-5.com) for complete information on patents and trademarks. For maximum holding strength, setscrews should be tensioned and re-tensioned as the seam material compresses. Clamp setscrew tension should be verified using a calibrated torque wrench between 160 and 180 inch pounds when used on 22ga steel, and between 130 and 150 inch pounds for all other metals and thinner gauges of steel. Consult the S-5! website at [www.S-5.com](http://www.S-5.com) for published data regarding holding strength.

Copyright 2013, Metal Roof Innovations, Ltd. S-5! products are patent protected. S-5! aggressively protects its patents, trademarks, and copyrights. Version 080813. These instructions are for use by those experienced in the trade. Always follow appropriate safety precautions and use appropriate tools.

**Using SnoClip™**

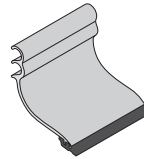

SnoClip II

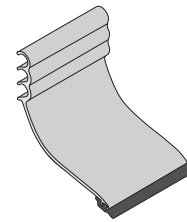

SnoClip III

**IMPORTANT NOTICE! — SnoClip™ design has changed. SnoClip must now slide on from the end of the ColorGard crossmember.** Be sure to slide SnoClip onto assembly before attaching crossmember to clamps (a new Retro-Fit SnoClip™ is also available from your authorized S-5!® distributor.) One SnoClip is used between seams (in rare cases two SnoClips may be desired; see [www.S-5.com](http://www.S-5.com) for details). Mount the SnoClip to the back of the ColorGard using the lock that results with the rubber "foot" resting properly on the panel surface. When applying downward pressure on the part, the "toe" should engage the surface of the panel just before the "heel." Periodic maintenance over time may be necessary to ensure that the SnoClips maintain the appropriate positioning, as snow weight may sometimes flip the clip up slightly.

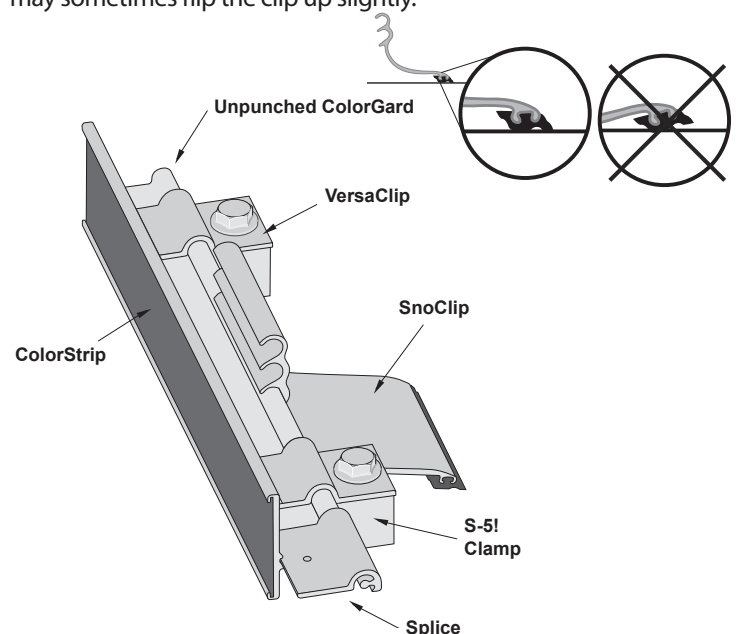





Rocky Mountain  
Snow Guards Inc



## Stocked Color Strip Inserts for Colorgard Snow Fence Systems

**Black**

**Charcoal Gray**

**Dark Bronze**

**Medium Bronze**

**Evergreen**

**ACTUAL COLORS MAY VARY**

**We strongly recommend obtaining a  
sample prior to purchasing.**

(877) 414-7606

[www.RockyMountainSnowGuards.com](http://www.RockyMountainSnowGuards.com)

## SECTION 07 72 53

### COLORGARD® SNOW GUARDS

#### PART 1 - GENERAL

##### 1.1 SUMMARY

- A. Section Includes:
  - 1. Snow guards for metal roofs.
  - 2. [Non-penetrating] [Face fastened] attachment system.

##### 1.2 RELATED SECTIONS

- A. Division 01: Administrative, procedural, and temporary work requirements apply to this section.
- B. Section 07 41 13 - Metal Roof Panels
- C. Section 07 61 00 - Sheet Metal Roofing
- D. Section 07 62 00 – Sheet Metal Flashing and Trim
- E. Section 07 72 55 - Roof Accessory Attachment System.
- F. Section 13 34 19 – Metal Building Systems

##### 1.3 REFERENCES

- A. Aluminum Association (AA) - Aluminum Standards and Data, 2003 Edition.
- B. ASTM International (ASTM):
  - 1. B85-03 - Standard Specification for Aluminum-Alloy Die Castings.
  - 2. B221-04a - Standard Specification for Aluminum and Aluminum-Alloy Extruded Bars, Rods, Wire, Profiles, and Tubes.

##### 1.4 SUBMITTALS

- A. Action Submittal:
  - 1. Shop Drawings: Include roof plans showing locations of snow guards on roof and attachment details and spacing.
  - 2. Product Data:
    - a. Product description.
    - b. Construction details.
    - c. Material descriptions.
    - d. Individual component dimensions.
    - e. Finishes.
    - f. Installation instructions.
  - 3. Samples:

- a. Clamp samples.
  - b. 12-inch long cross member samples including all associated hardware.
- B. Informational Submittals:
  - 1. Include calculation of number and location of snow guards based on designed roof snow load, roof slope, roof type, components, spacings and finish
  - 2. Test results: Results of product tensile load testing, issued by a recognized independent testing laboratory, showing ultimate load-to-failure value of attachment.
- C. Closeout Submittals:
  - 1. Certification: Installer's certification that snow guard system was installed in accordance with manufacturer's instructions and approved Shop Drawings.

## 1.5 QUALITY ASSURANCE

- A. Manufacturer Qualifications: Manufacturer to specialize in production of Snow Guard Products of the type specified with a minimum of 20 years documented experience.
- B. Installer Qualifications: Installer to specialize in metal roof installation and installation of Snow Guard Products with a minimum of 5 years documented experience.
- C. Mockup:
  - 1. Size: Minimum [8] [ ] feet long.
  - 2. Show: Snow guard attachment, cross members, and accessories.
  - 3. Locate [where directed.] [\_\_\_\_.]
  - 4. Approved mockup may remain as part of the Work.

## 1.6 DELIVERY, STORAGE AND HANDLING

- A. Deliver components to jobsite properly packaged to provide protection during transport, delivery and handling.
- B. Store products in manufacturer's original labeled and unopened packaging in a clean and dry location, protected from potential damage, until ready for application.

## PART 2 - PRODUCTS

### 2.1 SYSTEM DESCRIPTION

- A. Attachment system to provide attachment to standing seam metal roofs:
  - 1. With only minor dimpling of panel seams.
  - 2. Without penetrations through roof seams or panels.
  - 3. Without use of sealers or adhesives.
  - 4. Without voiding roof warranty.
- B. Performance Requirements: Provide snow guards to withstand exposure to the weather and environmental elements, and resist design forces without failure due to defective manufacture.
  - 1. Loading: Design snow guard system to resist minimum in-service vector load of [ ] pounds per linear foot of eave.
  - 2. Factor of safety: Utilize a factor of safety  $\geq$  [2] [ ] to determine allowable loads from ultimate tested clamp tensile load values.
  - 3. Source Limitation: Provide snow guard system as designed and tested by the manufacturer as a complete system. Install components by the same manufacturer.

### 2.2 MANUFACTURER

- A. Acceptable Manufacturer: S-5! Metal Roof Innovations, Ltd., 8655 Table Butte Road, Colorado Springs, CO. 80908; Tel: 888-825-3432; Fax: 719-495-0045; Email: [support@s-5.com](mailto:support@s-5.com); Web: [www.s-5.com](http://www.s-5.com)
- B. Substitutions: Not permitted.

### 2.3 BAR/RAIL-TYPE SNOW RETENTION SYSTEMS FOR STANDING SEAM METAL ROOFS

- A. Basis of Design: ColorGard, manufactured by S-5! Metal Roof Innovations, Ltd.
- B. Components:
  - 1. Clamps
    - a. Manufactured from 6061-T6 aluminum extrusions conforming to ASTM B221 or aluminum castings conforming to ASTM B85 and to AA Aluminum Standards and Data.
      - 1) Model: No. [S-5-U.] [S-5-S.] [S-5-T.] [S-5-Z.] [S-5-E.] [S-5-B.] [S-5-Q.] [S-5-H.] [S-5-K700.] [S-5-H90.] [S-5-N.] [S-5-N 1.5.] [S-5-KHD.] [S-5-V.] [S-5-K Grip.] [S-5-R465.]
    - b. Set screws: 300 Series stainless steel, 18-8 alloy, 3/8 inch diameter, with round nose point.
    - c. Attachment bolts: 300 Series stainless steel, 18-8 alloy, 8 mm or 10 mm diameter, hex flange bolt..
  - 2. Brackets:
    - a. Manufactured from 6061-T6 or 6005-T5 alloy and temper aluminum extrusions conforming to ASTM B221 and AA Aluminum Standards and Data or cast aluminum.
      - 1) Model: No. [VersaBracket 47.] [VersaBracket 67.] [CorruBracket.].
    - b. Screws for attachment of brackets to roof: Type best suited to application: Metal to metal applications: ¼-14 self drilling point, 2 inch length, 3/8 inch hex washer head, Zinc/Aluminum cap. Metal to wood applications: ¼-14 type 17 AB milled point, 2 inch length, 3/8 inch hex washer head, Zinc/Aluminum cap.
  - 3. Cross Members:
    - a. Manufactured from 6061-T6 or 6005-T5 alloy and temper aluminum extrusions conforming to ASTM B221 and AA Aluminum Standards and Data.
    - b. Receptacle in face to receive color-matched metal strips.
    - c. Provide splice connectors ensuring alignment and structural continuity at end joints.
  - 4. Color Strips: Same material and finish as roof panels; obtained from roof panel manufacturer.
  - 5. Snow and Ice Clips:
    - a. Aluminum, with rubber foot, minimum 3 inches wide.
      - 1) Model: SnoClip II or SnapClip II for standing seam heights 1” to 1.75”
      - 2) Model: SnoClip III or SnapClip III for standing seam heights 1.75” to 3”

## PART 3- EXECUTION

### 3.1 EXAMINATION

Prior to beginning installation, verify that:

- 1. Panel seaming is complete.
- 2. Panel attachment is sufficient to withstand loads applied by snow guard system.
- 3. Installation will not impeded roof drainage.

Prior to beginning installation, verify that:

1. Roof attachment is sufficient to withstand loads applied by snow guard system.
2. Installation will not impede roof drainage.

### 3.2 PREPARATION

- A. Clean areas to receive attachments; remove loose and foreign matter that could interfere with installation or performance.

### 3.3 INSTALLATION

- A. Install system in accordance with manufacturer's instructions and approved Shop Drawings

- B. ColorGard Snow Retention System:

1. Place clamps at maximum 32 inches on center or as required by in-service loads.
2. Place clamps in straight, aligned rows.
3. Place both set screws on same side of clamp.
4. Tighten set screws to manufacturer's recommended torque. Randomly test set screw torque using calibrated torque wrench.
5. Insert color-matched metal strips into cross members, staggering strips to cover cross member joints.
6. Attach cross members to clamps; tighten bolts to manufacturer's recommended torque.
7. Install splice connectors at cross member end joints.
8. Do not cantilever cross members more than 4 inches beyond last clamp at ends.
9. Install [one SnoClip or SnapClip] [two SnoClips or SnapClips] per panel between panel seams.
  - a. SnoClips: slide onto cross member before securing cross member to clamps
  - b. SnapClips: Secure [SnapClip II] [SnapClip III] to back side of cross member using stainless steel #10 x ½ inch screw

1. Place brackets at maximum 32 inches on center or as required by in-service loads.
2. Clean roof area to receive bracket. Remove protective seal on butyl tape
3. Place brackets in straight rows along underlying substrate.
4. Insert color-matched metal strips into cross members.
5. Place brackets at spot of attachment and fasten with screws best suited for type of attachment
6. Attach cross members to brackets using self drilling screws.
7. Install splice connectors at cross member end joints.
8. Do not cantilever cross members more than 4 inches beyond last bracket at ends.

9. Install SnoClips or SnapClips at spacings indicated on Shop Drawings.
  - c. SnoClips: slide onto cross member before securing cross member to clamps
  - d. SnapClips: Secure [SnapClip II] [SnapClip III] to back side of cross member using stainless steel #10 x ½ inch screw (provided).

END OF SECTION



# Rocky Mountain Snow Guards Inc

ROCKY MOUNTAIN SNOW GUARDS  
4231 S. NATCHES COURT, UNIT C  
ENGLEWOOD, CO 80110  
PHONE: (877) 414-7606  
FAX: (720) 387-8361  
[www.rockymountainsnowguards.com](http://www.rockymountainsnowguards.com)

## Rocky Mountain Snow Guards Snow Retention System Maintenance Guide

Systems designed by Rocky Mountain Snow Guards, installed properly should last the life of the roof. Rocky Mountain does not recommend adhesive tape or sealant attachment for any snow fence or snow guard system. Rocky Mountain snow retention systems installed on commercial buildings, above high traffic areas or in areas with high snow loads should be inspected by a qualified roofing or snow retention professional on an annual basis to ensure the system will continue to perform as designed.

### Bolt Down Snow Fence Systems:

1. Inspect brackets, snow fence components and fasteners for evidence of damage.
2. Replace damaged parts prior to the next snow season.

### Clamp to Seam Snow Fence and Snow Bar Systems:

1. Inspect brackets, snow fence and snow bar components for evidence of damage.
2. Replace damaged parts prior to the next snow season.
3. Check torque on set screws with an appropriate torque wrench.
4. Torque set screws to recommended torque. This is especially important after the 1st snow season.

### Snow Guards:

1. Inspect snow guards for evidence of damage.
2. Inspect exposed fasteners.
3. Replace damaged parts prior to the next snow season.