



# Rocky Mountain Snow Guards Inc

ROCKY MOUNTAIN SNOW GUARDS  
4231 S NATCHES CT., UNIT C  
ENGLEWOOD, CO 80110  
PHONE: (720) 379-7756  
FAX: (720) 387-8361  
[www.rockymountainsnowguards.com](http://www.rockymountainsnowguards.com)

## S-5® ColorGard SNOW BAR SYSTEM

### AVAILABLE MATERIALS:

- ALUMINUM
- BRASS (S-5® B-CLAMP ONLY)



Unpunched ColorGard Bar with S Clamps, Veraclips and SnoClip II, Rear

### INFORMATION:

- 7'8" Unpunched bar
- Clamps to fit all seam profiles
- Specific load ratings for all panels
- Excellent Choice for:
  - Standing seam metal panel roofs
  - Through-fastened metal panels (Versabacket)
  - Corrugated metal panels (Corrubacket)

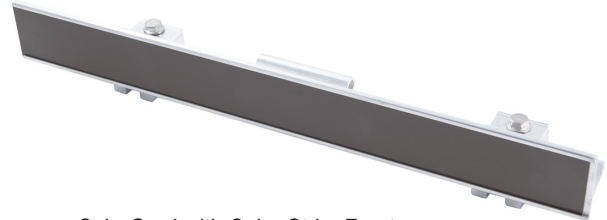

ColorGard with Color Strip, Front

### EXAMPLES:



# S-5!<sup>®</sup>

## The Right Way!<sup>®</sup>

### S-5-K Grip Snow Clamp

The S-5-K Grip Snow clamp was specifically developed to fit Klip-Rib<sup>®</sup> and other bulb snap-together seams. The design utilizes multiple inserts (sold separately) in order to accommodate a variety of bulb snap-together profiles. Each insert has a unique shape that allows for a tight fit and provides increased holding strength over other attachment options. This product is designed and tested to work with ColorGard<sup>®</sup>.

The S-5-K Grip Snow also eliminates the large moment arm other clamps use for these profiles. Instead, it features a low mounting surface area, with the mounting bolt directly over the center of the seam. This dramatically increases the strength of the clamp, making it perfect for use with heavy-duty applications.

The head of the flanged bolts control the amount of compression, which reduces the possibility of over-compressing the seam, and makes installation a snap!

Just place the clamp on the seam, position the insert piece, and tighten the flanged bolts at the base. Then, affix ancillary items using the top bolt provided. Go to: [www.S-5.com/tools](http://www.S-5.com/tools) for information about properly attaching S-5!<sup>®</sup> clamps.

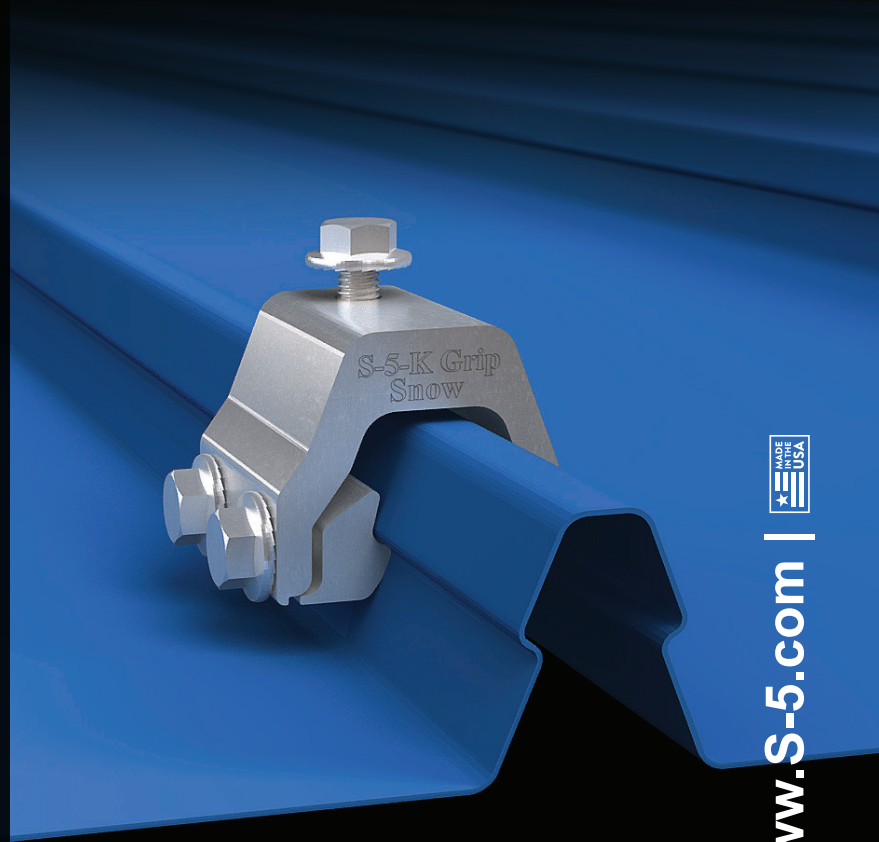

The S-5-K Grip Snow was specifically developed to attach ColorGard<sup>®</sup> snow retention system to Klip-Rib<sup>®</sup> and other bulb snap-together seams.

The right way to attach almost anything to metal roofs!

S-5-K Grip Snow



888-825-3432 | [www.S-5.com](http://www.S-5.com) |

The S-5-K Grip Snow eliminates the large moment arm and features a low mounting surface area with the mounting bolt directly over the center of the seam, which dramatically increases the strength of the clamp.

The S-5-K Grip Snow clamp is furnished with the hardware shown to the right. The clamp is provided with an M8-1.25 X 16.00 mm Hex Flange Bolt. A structural aluminum attachment clamp, the S-5-K Grip Snow is compatible with most common metal roofing materials excluding copper and is designed to accommodate the S-5!<sup>®</sup> ColorGard<sup>®</sup> snow retention system. All included hardware is stainless steel. Please visit [www.S-5.com](http://www.S-5.com) for more information including CAD details, metallurgical compatibilities, and specifications.

The S-5-K Grip Snow clamp has been tested for load-to-failure results on a variety of standing seam roof profiles from leading panel manufacturers. When placed near a clip location, the S-5-K Grip Snow achieves unsurpassed holding strength, dramatically reducing the need for multiple rows of snow retention in regions with heavy snow loads. The independent lab test reports found on our website at [www.S-5.com](http://www.S-5.com) prove that S-5!<sup>®</sup> holding strength is unmatched in the industry.

An S-5-K Grip clamp compatible with an M10-1.5 X 16.00 mm Hex Flange Bolt is available upon request for an additional up charge.

## Example Profile

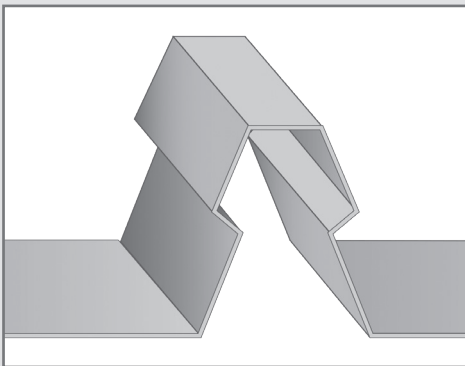

## S-5-K Grip Snow

(With S-5-GX 10 Insert)

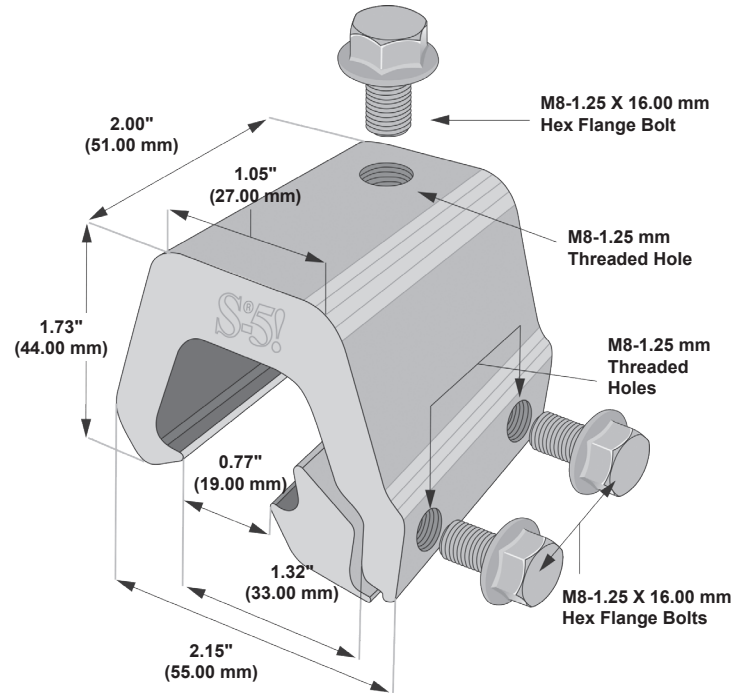

## Insert Options

## Profiles

### S-5-GX 10

- LYSAGHT KLIP-LOK<sup>®</sup> 406
- McElroy Metal Mirage
- AEP Span Klip-Rib<sup>®</sup>
- Metal Sales Clip-Loc
- SpeedDeck<sup>®</sup> SpeedDeck<sup>®</sup>
- Safintra Saflok 410
- Safintra Saflok 700
- And other similar profiles

### S-5-GX 50

- LYSAGHT KLIP-LOK Classic<sup>®</sup> 700
- LYSAGHT KLIP-LOK 700 Hi-Strength<sup>®</sup>
- Stramit Speed Deck Ultra<sup>®</sup>
- Fielders KingKlip<sup>®</sup> 700
- And other similar profiles

If you have a profile not listed here, please contact S-5! to request a sample for testing.

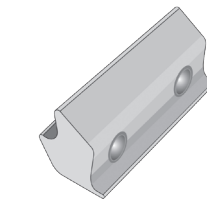

S-5-GX 10 Insert

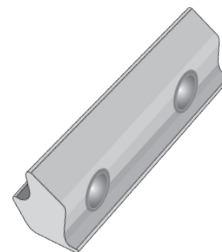

S-5-GX 50 Insert

### S-5!<sup>®</sup> Warning! Please use this product responsibly!

Products are protected by multiple U.S. and foreign patents. For published data regarding holding strength, fastener torque, patents, and trademarks, visit the S-5! website at [www.S-5.com](http://www.S-5.com).

Copyright 2021, Metal Roof Innovations, Ltd.  
S-5! aggressively protects its patents, trademarks, and copyrights. Version 081321.

Distributed by

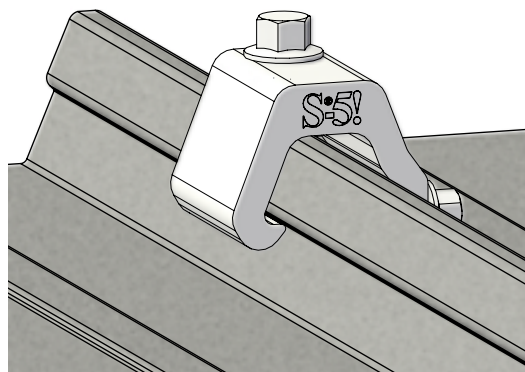

# **S-5-K SNOW GRIP**

## **S-5-GX 10 (INSERT)**

M8-1.25 THREADED HOLE

TOP

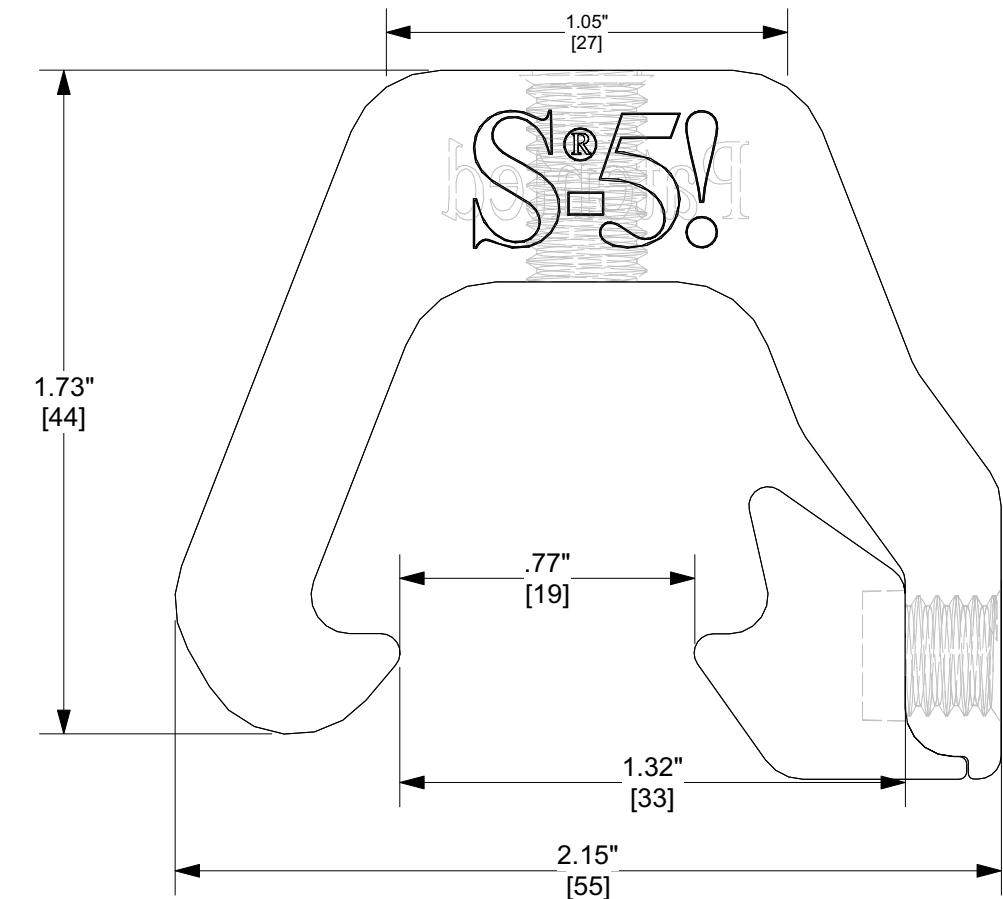
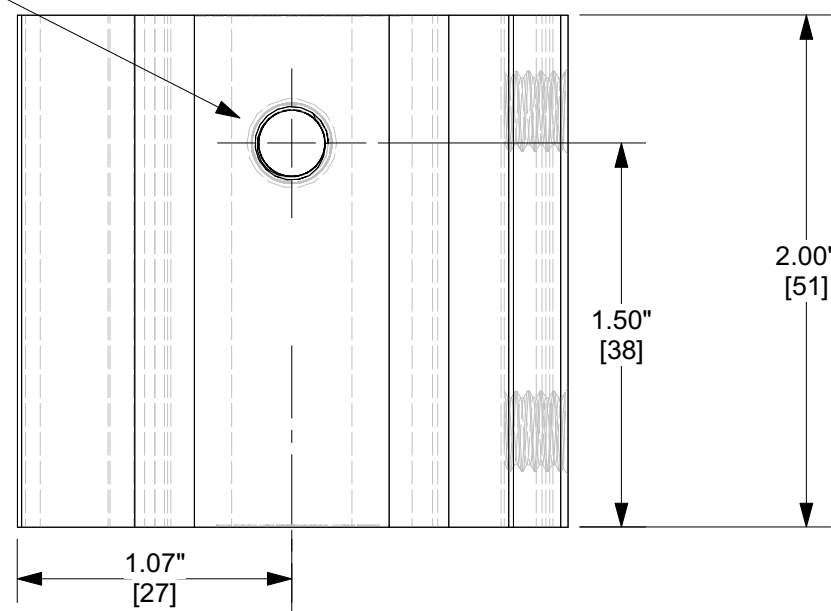

SCALE: 2X

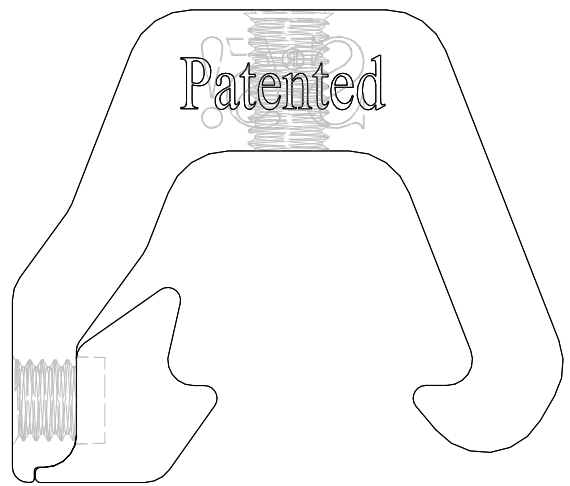

BACK

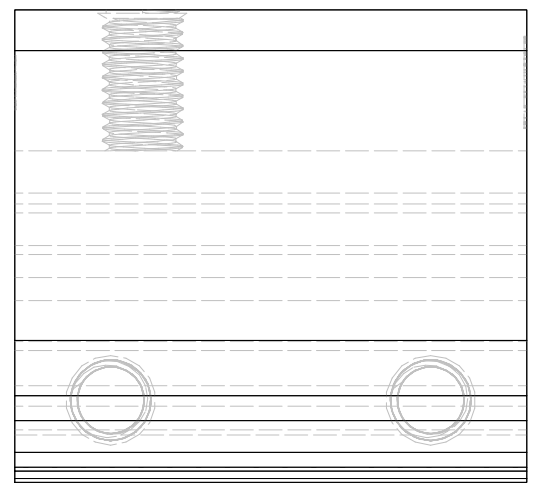

LEFT

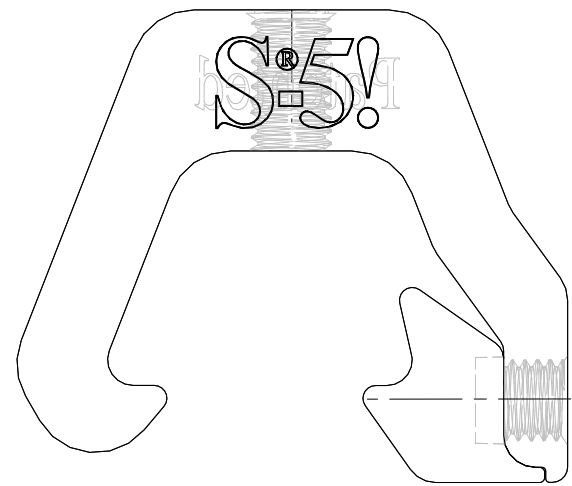

FRONT

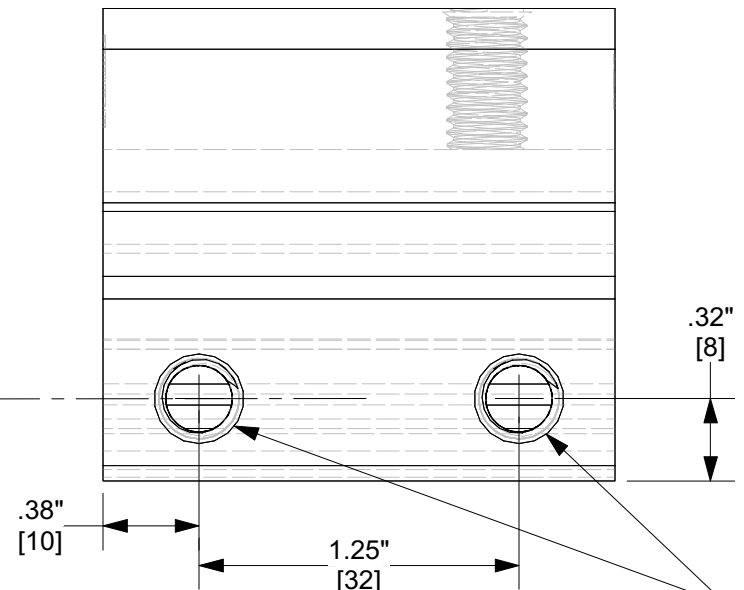

RIGHT

(2X) M8-1.25 THREADED HOLE

**General Notes**

1. S-5-K GRIP SNOW
2. S-5-GX10 INSERT
3. M8-1.25 16 mm LENGTH 13 mm HEX FLANGE BOLT
4. EXAMPLE ROOF PROFILE

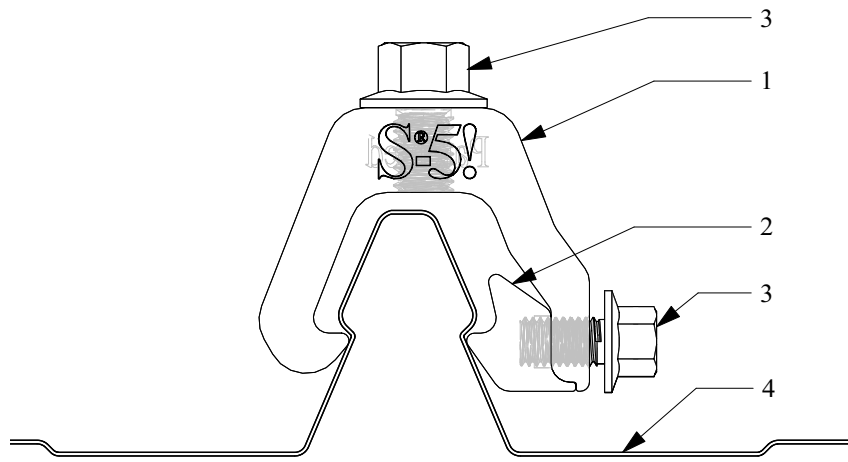

**FOR STANDING SEAM SPECIFIC MECHANICAL LOAD TEST INFORMATION AND CLAMP INSTALLATION INFORMATION PLEASE VISIT: WWW.S-5.COM**

MATERIAL: <b>6000 SERIES AL</b>	 <p><b>S-5!</b> The Right Way!</p>	METAL ROOF INNOVATIONS, LTD. 8655 TABLE BUTTE RD COLORADO SPRINGS, CO 80908 719-495-0518 719-495-0045 (FAX)	
EST ASSEMBLY WEIGHT :			
SUPPLIED HARDWARE: <small>(3) M8-1.25 X 16MM (13MM HEX) 18/8 SS</small>	TITLE S-5-K GRIP WITH GX 10 INSERT		
SCALE: <b>1:0.75</b>	DRAWING NO. KG47-A 2013	DRAWN BY MS	DATE 02/15/2013
OTHER:	<small>S-5!® PRODUCTS ARE PROTECTED BY MULTIPLE U.S. PATENTS INCLUDING 5,228,248, 5,983,588 AND 6,164,033 (OTHERS ISSUED AND PENDING). EUROPEAN PATENTS ARE ALSO APPLIED FOR AND PENDING UNDER THE PATENT COOPERATION TREATY WITH DIVISIONAL FILING RIGHTS RETAINED. METAL ROOF INNOVATIONS, LTD. (LICENSOR OF S-5!® TECHNOLOGY) AGGRESSIVELY PROSECUTES PATENT INFRINGEMENT.</small>		

## Installation Instructions

**S-5!<sup>®</sup> Warning!** Please use these products responsibly! Visit our website or contact your S-5! distributor for available load test results. The user and/or installer of these parts is responsible for all necessary engineering and design to ensure the S-5-K Grip Snow has been properly spaced and configured.

**Notice to S-5! product users:** Due to the many variables involved with specific panel products, climates, snow melt phenomena, and job particulars, the manufacturer cannot and does not express any opinions as to the suitability of any S-5! assembly for any specific application and assumes no liability with respect thereto. S-5! products are tested for ultimate holding strength on various profile types and materials. This information is available from the S-5! website: [www.S-5.com](http://www.S-5.com). This document is an installation guide only and the photographs and drawings herein are for the purpose of illustrating installation tools and techniques, not system designs.

**The S-5-K Grip Snow clamp is designed to fit Klip Rib<sup>®</sup> and other bulb snap-together seams. This product is designed and tested to work with ColorGard<sup>®</sup> and X-Gard<sup>™</sup> snow retention systems.**

The S-5-K Grip Snow utilizes multiple inserts (sold separately) in order to accommodate a variety of bulb snap-together profiles. Each insert has a unique shape that allows for a tight fit and provides increased holding strength over other attachment options.

The appropriate seam profiles for each insert option are listed on the back of these installation instructions.

The heads of the clamp's M8-1.25 X 13 mm Hex Flange Bolts control the amount of compression, which reduces the possibility of over-compressing the seam, and makes installation a snap!

## Tools Needed

- Dial-Calibrated Torque Wrench\*  
(\*For accurate tension values, do NOT use a clicking torque wrench)

## To Install S-5-K Grip Snow

**For use with ColorGard:** If the ColorGard assembly utilizes the VersaClip<sup>™</sup> for attachment of the ColorGard crossmember to the clamps, the bolt hole in the clamp should be at the upslope end of the clamp. If the assembly uses punched ColorGard without VersaClip, the hole should be at the downslope end of the clamp.

**For use with X-Gard:** The bolt hole in the clamp should always be at the upslope end of the clamp.

1. Position clamp insert at desired location along the rib, just under the fold of the rib. Clamp placement MUST be located within 2" upslope of concealed clip (not directly over clip locations).
2. Roll the clamp into position over the seam and clamp insert piece. Position the clamp so that it is centered over the clamp insert with approximately 2 mm of insert overhang on each side of the clamp.
3. Partially thread the two bolts into the base of the S-5-K Grip Snow by hand. The bolts should engage the divots in each end of the S-5-K Grip Snow insert.
4. Tighten the bolts at the base of the S-5-K Grip Snow using a ratchet or screw gun with a 13 mm hex. For optimal holding strength, bolts should be tensioned to 20 inch pounds.
5. Secure S-5! ColorGard snow retention system to clamps according to ColorGard installation instructions.

These instructions are for use by those experienced in the trade. Always follow appropriate safety precautions and use appropriate tools.

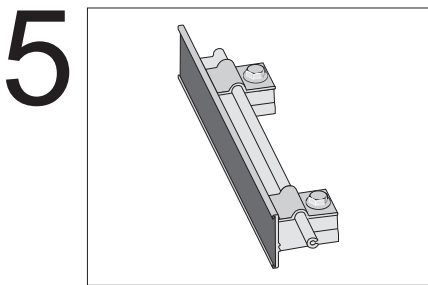
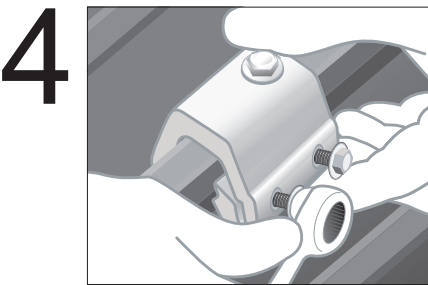
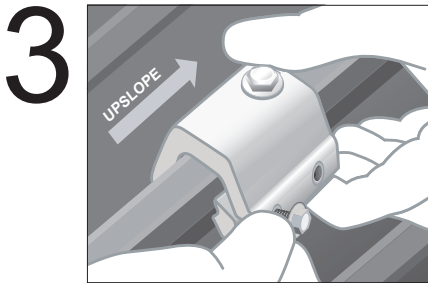
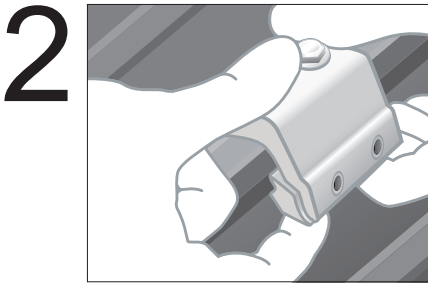
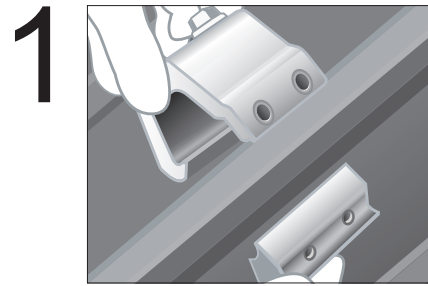

### Seam Profiles

**S-5-K Grip Snow is designed to fit Klip-Rib® and other bulb snap-together seams.**

**Seam profiles for the S-5-GX 10 insert:**

- LYSAGHT KLIP-LOK® 406
- McElroy Metal Mirage
- AEP Span Klip-Rib®
- Metal Sales Clip-Loc
- SpeedDeck® SpeedDeck®
- Safintra Saflok 410
- Safintra Saflok 700
- Domico GBS Domitec® Dach
- And other similar profiles

**Seam profiles for the S-5-GX 50 insert:**

- LYSAGHT KLIP-LOK Classic® 700
- LYSAGHT KLIP-LOK 700 Hi-Strength®
- Stramit Speed Deck Ultra®
- Fielders KingKlip® 700
- And other similar profiles

If you have a profile not listed here, please contact S-5!® to request a sample for testing.

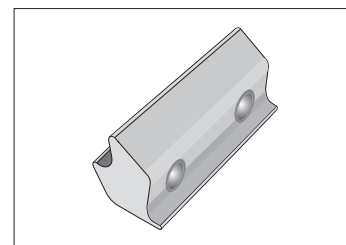

**S-5-GX 10 Insert**

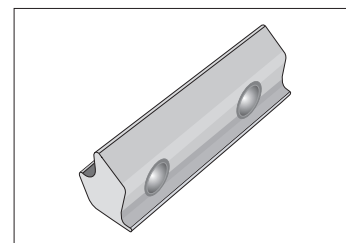

**S-5-GX 50 Insert**

#### **S-5!® Warning! Please use this product responsibly!**

S-5!® Warning! Please use this product responsibly! Products are protected by multiple U.S. and foreign patents. For published data regarding holding strength, fastener torque, patents, and trademarks, visit the S-5! website at [www.S-5.com](http://www.S-5.com).

Copyright 2014, Metal Roof Innovations, Ltd. S-5! products are patent protected.

S-5! aggressively protects its patents, trademarks, and copyrights. Version 102714.

# ColorGard<sup>®</sup> 2.0 *Installation Instructions*

Providing *The Right Way*<sup>™</sup> to attach virtually anything to metal roofs worldwide.

**S-5!**<sup>®</sup>  
*The Right Way*

**ATTENTION!** This document is a guide only. This product may not be suitable for every application. The user is responsible for all necessary application engineering and design. We have online tools to help with this. Please scan the QR code to the right for additional information, warnings and disclaimers regarding product use.

You can also view load test results at [www.S-5.com](http://www.S-5.com) where applicable, or contact your S-5!<sup>®</sup> distributor for more information.



## ⚠ ATTENTION INSTALLERS ⚠

**PLEASE READ THESE INSTRUCTIONS ALL THE WAY THROUGH BEFORE BEGINNING WORK.  
IT WILL SAVE TIME, MONEY AND PREVENT MISTAKES!**

## Components

### Crossmember and Splice

Unpunched and punched crossmembers are available. Use the included splice to join two pieces of crossmember together, ensuring structural continuity. ColorGard 2.0 now accommodates a wider allowable span, up to 42-inch seam spacings.

Crossmember

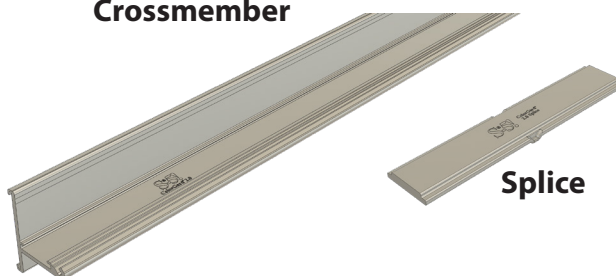

Splice

### SnoClip<sup>™</sup> 2.0

SnoClip can be added to slow the migration of snow and ice beneath the crossmembers. Simply hinge it onto the ColorGard crossmember during or following installation and secure the fastener to engage the SnoClip foot onto the roof.

SnoClip 2.0 II

SnoClip 2.0 III



### VersaClip<sup>™</sup> 2.0

VersaClip is placed "on the fly" as the ColorGard crossmember is installed. (No preassembly)

VersaClip 2.0

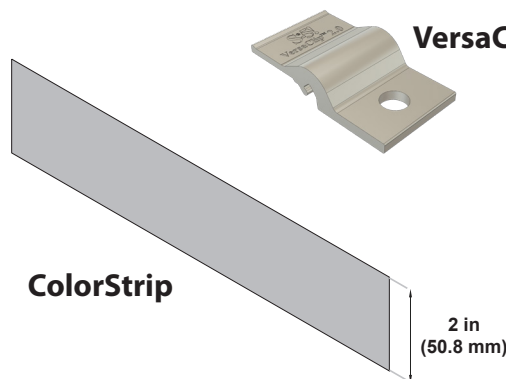

ColorStrip

2 in  
(50.8 mm)

### ColorStrip<sup>™</sup>

**Not included:** The **ColorStrip** can be obtained in **2-inch (50.8 mm) wide strips** by the roofing material manufacturer to ensure a perfect color match and durability.

**Note:** It is recommended to have the ColorStrip **sheared**, not slit, during manufacturing to maintain clean edges and optimal performance. Use **tin snips** to trim the ColorStrip to the required length on-site as needed.

## Tools Required:

- Screw Gun
- 13mm Socket for Impact or Ratchet [Box-End Hand Wrench Optional]
- Reciprocating Saw or Circular Saw with Non-Ferrous Blade [minimal use]
- String Line
- Calibrated Dial Indicating Torque Wrench
- Vice Grip Pliers

# How to Install ColorGard:

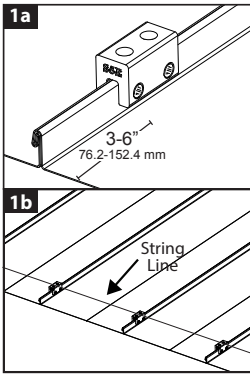

## 1 INSTALLING S-5! CLAMPS/BRACKETS

### Step 1a: Preparing the Clamps/Brackets

- I. Review the **S-5! instructions** for your specific S-5! clamps or brackets. Read these instructions to the end before beginning work—it will save time and avoid mistakes.
- II. Attach a clamp/bracket within **3-6" (76.2-152.4 mm) of the eave** at both ends of the planned installation area.

### Step 1b: Aligning Clamps/Brackets with a String Line

- I. Stretch a **tight string line** between the two end clamps/brackets.
  - Make sure the line is taut to avoid sagging or being affected by wind.
- II. Then install all clamps/brackets to line at their predetermined spacing.

**Note for Longer Assemblies:** For installations that span longer distances, additional intermittent clamps or brackets should be used at intervals to stabilize and anchor the string line securely in place.

## 2 INSTALLING THE COLORGARD CROSSMEMBER

### Step 2a: Place the Crossmember

- I. Position the crossmember **downslope** of the installed S-5! clamps/brackets.

### Step 2b: Attaching the Crossmember

#### For Unpunched Crossmembers:

- Place the **VersaClip** on the crossmember at each clamp/bracket location.
- Secure the crossmember using the provided **stainless steel M8 bolts** through the **upslope** clamp hole.
- Leave the bolts **loosely tightened** to allow for adjustments as the assembly progresses.

#### For Punched Crossmembers:

- Secure it using an **M8 bolt** through the **downslope** clamp hole (no VersaClip required).
- Leave the bolts **loosely tightened** to allow for adjustments as the assembly progresses.

### Step 2c: Tightening the Bolts

**Note:** if installing ColorStrip, please read Step 3 before tightening the bolts.

- I. Once the entire assembly is aligned and adjustments are complete, tighten all bolts progressively to achieve or exceed the specified torque: **160 inch-pounds (18 Nm)** for unpunched/punched crossmembers

### Step 2d: Connecting Crossmembers with Splices

- I. Insert a **splice piece** at each joint between crossmembers to maintain structural integrity.
  - If trimming the crossmember at the end of assembly, ensure the crossmember does not cantilever more than **8" beyond the last clamp/bracket**.
  - Secure trimmed sections with **at least two** clamps/brackets.

**Note:** For unpunched crossmembers at splices, the VersaClip can be placed directly at the clamp/bracket location if needed.

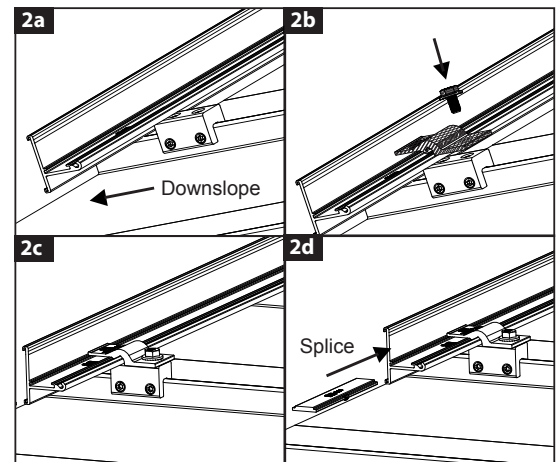

## 3 INSTALLING THE COLORSTRIP

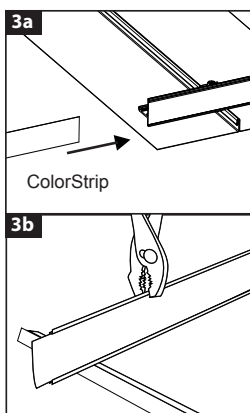

### Step 3a: Insert the ColorStrip

- I. As you assemble the system, slide the **ColorStrip** into the crossmembers while the bolts remain loose to allow for smooth insertion of the strip
- II. Stagger the joints of the ColorStrip from the crossmember joints to conceal connections.
- III. Overlap adjacent ColorStrips by **.5 inch (13 mm)**

### Step 3b: Secure the ColorStrip

- I. Use **vice grip pliers** to pinch the retainer lip of the crossmember at various points along its length. This prevents the ColorStrip from shifting laterally during or after installation.

## 4 INSTALLING THE SNOCLIP

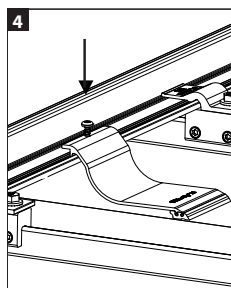

### I. Position the SnoClip

- For one SnoClip per panel, center it on the crossmember between two clamps/brackets.
- For two or more SnoClips per panel, space them evenly between the clamps/brackets to ensure uniform support.

### II. Attach the SnoClip

- Hinge the SnoClip directly onto the crossmember.
- Ensure the rubber foot engages the surface of the panel for proper functionality.

### III. Secure the SnoClip

Drive the included fastener through the prepunched hole in the SnoClip into the crossmember channel using the T30 from clamp installation. Tighten the screw to approximately 50 inch-pounds (5-6 Nm) to secure the SnoClip firmly. (if the screw head shears during installation do not be alarmed as it will not inhibit proper function)

**SnoClip 2.0 II**  
Designed for Seam Heights of 1" - 2"

**SnoClip 2.0 III**  
Designed for Seam Heights of 2" - 3¼"

Note: Any S-5! warranty and/or calculation may be void if hardware is used that was not furnished by S-5! directly or through one of their licensed distributors or any assembly that has not been tested by S-5! These instructions are for use by those experienced in the trade. Always follow appropriate safety precautions and use appropriate tools.

**S-5!® Warning! Please use product responsibly!**

S-5!® Warning! Please use this product responsibly! Products are protected by multiple U.S. and foreign patents. For published data regarding holding strength, fastener torque, patents and trademarks, visit the S-5! website at [www.s-5.com](http://www.s-5.com). Copyright 2025, Metal Roof Innovations, Ltd. S-5! products are patent protected. S-5! aggressively protects its patents, trademarks and copyrights. 013125



Rocky Mountain  
Snow Guards Inc



## Stocked Color Strip Inserts for Colorgard Snow Fence Systems

**Black**

**Charcoal Gray**

**Dark Bronze**

**Medium Bronze**

**Evergreen**

**ACTUAL COLORS MAY VARY**

**We strongly recommend obtaining a  
sample prior to purchasing.**

(877) 414-7606

[www.RockyMountainSnowGuards.com](http://www.RockyMountainSnowGuards.com)



# Rocky Mountain Snow Guards Inc

ROCKY MOUNTAIN SNOW GUARDS  
4231 S. NATCHES COURT, UNIT C  
ENGLEWOOD, CO 80110  
PHONE: (877) 414-7606  
FAX: (720) 387-8361  
[www.rockymountainsnowguards.com](http://www.rockymountainsnowguards.com)

## Rocky Mountain Snow Guards Snow Retention System Maintenance Guide

Systems designed by Rocky Mountain Snow Guards, installed properly should last the life of the roof. Rocky Mountain does not recommend adhesive tape or sealant attachment for any snow fence or snow guard system. Rocky Mountain snow retention systems installed on commercial buildings, above high traffic areas or in areas with high snow loads should be inspected by a qualified roofing or snow retention professional on an annual basis to ensure the system will continue to perform as designed.

### Bolt Down Snow Fence Systems:

1. Inspect brackets, snow fence components and fasteners for evidence of damage.
2. Replace damaged parts prior to the next snow season.

### Clamp to Seam Snow Fence and Snow Bar Systems:

1. Inspect brackets, snow fence and snow bar components for evidence of damage.
2. Replace damaged parts prior to the next snow season.
3. Check torque on set screws with an appropriate torque wrench.
4. Torque set screws to recommended torque. This is especially important after the 1st snow season.

### Snow Guards:

1. Inspect snow guards for evidence of damage.
2. Inspect exposed fasteners.
3. Replace damaged parts prior to the next snow season.

## SECTION 07 72 53

### SNOW GUARDS

This section has been prepared by Metal Roof Innovations, Ltd. for use in the preparation of a project specification. Attachment may be by one of the following methods:

#### **PART 1 - GENERAL**

##### 1.1 SUMMARY

- A. Section Includes:
  - 1. Snow guards for metal roofs.
  - 2. **[Non-penetrating] [Face-fastened]** attachment system.

##### 1.2 RELATED SECTIONS

- A. Division 01: Administrative, procedural and temporary work requirements apply to this section.
- B. Section 07 41 13 – Metal Roof Panels
- C. Section 07 61 00 – Sheet Metal Roofing
- D. Section 07 62 00 – Sheet Metal Flashing and Trim
- E. Section 07 72 53 – Roof Accessories – Snow Guards
- F. Section 13 34 19 – Metal Building Systems

##### 1.3 REFERENCES

- A. Aluminum Association (AA) - Aluminum Standards and Data, Current Edition.
- B. ASTM International (ASTM):
  - 1. A484/A484M-16 – Standard Specifications for General Requirements for Stainless Steel Bars, Billets and Forgings.
  - 2. A554-16 – Standard Specification for Welded Stainless Steel Mechanical Tubing.
  - 3. A555/A555M-16 – Standard Specification for General Requirements for Stainless Steel Wire and Wire Rods.
  - 4. B85-03 – Standard Specification for Aluminum-Alloy Die Castings.
  - 5. B221-04a – Standard Specification for Aluminum and Aluminum-Alloy Extruded Bars, Rods, Wire, Profiles and Tubes.
  - 6. F836M-02 (Current) – Standard Specification for Style 1 Stainless Steel Metric Nuts (Metric).
  - 7. F880-12 – Standard Specification for Stainless Steel Socket, Square Head, Torx and Slotted Headless-Setscrews.
- C. ICC Evaluation Service ([www.icc-es.org](http://www.icc-es.org)):

1. Division: 05 00 00 – METALS; Section: 05 05 23 – METAL FASTENERS Evaluation Report ESR-3869.
- D. IAPMO Uniform Evaluation Services
1. IAPMO UES EC 029-2018; Division: 05 00 00 – METALS; 05 05 23 METAL FASTENINGS; UES Evaluation Report Number: 805

#### 1.4 SUBMITTALS

- A. Action Submittal:
1. Shop Drawings: Include roof plans showing locations of snow guards on roof and attachment details and spacing.
  2. Product Data:
    - a. Product description.
    - b. Construction details.
    - c. Material descriptions.
    - d. Individual component dimensions.
    - e. Finishes.
    - f. Installation instructions.
  3. Samples:
    - a. **[Clamp][Bracket]** samples.
    - b. 12-inch long cross member samples including all associated hardware.
- B. Informational Submittals:
1. Proof of Job Specific Engineering: Include registered professional engineer wet-stamped calculation for number and frequency of snow guard attachments based on designed roof snow load, roof slope, roof dimensions, specific roof profile name, material type, gauge thickness and brand of manufacture; brand and model of snow retention device.  
**[(<https://s-5.com/snow-calculator/>)]**
  2. Proof of Product Testing: Results of appropriate product tensile load testing, issued by a recognized ISO 17025 accredited independent testing laboratory, showing the mean (of a minimum three test pulls) ultimate load-to-failure value of attachment **[bracket] [clamping device]** proposed on the specimen material named in B.1.
  3. Proof of Certified Production: Copy of manufacturer current ISO 9001 certificate (latest edition).
  4. Proof of Best Practice Compliance: Manufacturer duly executed letter stating full compliance with all provisions of the Metal Construction Association technical bulletin, “Qualifying Snow Retention Systems for Metal Roofing” (latest edition).
- C. Closeout Submittals:
1. Certification: Installer's certification or duly executed letter stating snow guard system was installed in accordance with manufacturer's instructions and approved shop drawings.

#### 1.5 QUALITY ASSURANCE

- A. Manufacturer Qualifications: Manufacturer to specialize in production of snow guard products of the type specified with a minimum of 10 years documented experience.
- B. Manufactured in an ISO 9001 (current) certified facility; ICC audited facility.
- C. Installer Qualifications: Installer to specialize in metal roof installation and installation of snow guard products with a minimum of 5 years documented experience.
- D. Mockup:
1. Size: Minimum **[8]**  feet long.
  2. Show: Snow guard attachment, cross members, and accessories.
  3. Locate **[where directed]** .

4. Approved mockup may remain as part of the Work.

E. Warranty:

1. Lifetime material/workmanship warranty on all products.
2. System performance warranty.

1.6 DELIVERY, STORAGE AND HANDLING

- A. Deliver components to jobsite properly packaged to provide protection during transport, delivery and handling.
- B. Store products in manufacturer's original labeled and unopened packaging in a clean and dry location, protected from potential damage, until ready for application.

**PART 2 - PRODUCTS**

2.1 SYSTEM DESCRIPTION

- A. Attachment system to provide attachment to standing seam metal roofs:
  1. With dimpling deformation of panel seams only at setscrew locations.
  2. Without penetrations through roof seams or panels.
  3. Without use of sealants or adhesives.
  4. Without violation of roof warranty.
- A. Attachment system to provide attachment to **[trapezoidal] [corrugated]** exposed-fastened metal roofs:
  1. Factory-applied butyl sealant.
  2. Without use of sealants or adhesives.
- B. Performance Requirements: Provide snow guards to withstand exposure to the weather and environmental elements and resist design forces without failure due to defective material or manufacture.
  1. Loading: Design snow guard system to resist minimum design roof snow load(s) **[of \_\_.] [See structural drawings for roof design snow loads.]**
  2. Factor of Safety: Utilize a factor of safety  $\geq$  **[2] [\_\_\_\_]** to determine allowable loads from ultimate tested **[clamp][bracket]** tensile mean load values.
  3. Source Limitation: Provide snow guard system as designed and tested by the manufacturer as a complete system. Install all system components by the same manufacturer.

2.2 MANUFACTURER

- A. Basis of Design: S-5!<sup>®</sup> div. of Metal Roof Innovations, Ltd., 500 W. Highway St., Iowa Park, TX 76367; Tel: 888-825-3432; Fax: 719-495-0045; Email: [support@s-5.com](mailto:support@s-5.com); Web: [www.s-5.com](http://www.s-5.com)
- B. Acceptable Manufacturers if products meet specification requirements:
  1. S-5!<sup>®</sup> div. of Metal Roof Innovations, Ltd. <https://www.s-5.com/>
  2. LMCurbs. <https://www.lmcurbs.com/>
  3. Rocky Mountain Snow Guards Inc. <https://www.rockymountainsnowguards.com/>
- C. Substitutions: [Under provisions in Division 1.] Not permitted.

## 2.3 CONTINUOUS, COLOR-MATCHING – TYPE SNOW RETENTION SYSTEMS FOR [STANDING SEAM] [EXPOSED-FASTENED] [EXPOSED-FASTENED, TRAPEZOIDAL-RIBBED INSULATED METAL PANEL] METAL ROOFS

A. Basis of Design: ColorGard®, manufactured by S-5! div. of Metal Roof Innovations, Ltd.

B. Components:

1. Clamps:

- a. Manufactured from 6000-series aluminum extrusions conforming to ASTM B221 or aluminum castings conforming to ASTM B85 and to AA Aluminum Standards and Data.
  - 1) Clamp model to be as recommended by the manufacturer for the specific seam profile used on the project.
- b. Setscrews: 300-series stainless steel, 18-8 alloy, 3/8 inch (9.525 mm) diameter, with round nose point.
- c. Attachment bolts: 300-series stainless steel, 18-8 alloy, 8 mm diameter, hex flange bolt.

2. Brackets:

- a. Manufactured from 6000-series alloy and temper-aluminum extrusions conforming to ASTM B221 and AA Aluminum Standards and Data.
  - 1) Model: [VersaBracket 47.] [VersaBracket 67.] [CorruBracket.] [SnoBracket.]
- b. Screws for attachment of brackets to roof: as specifically tested to the substrate used on the project, and furnished by snow guard manufacturer. All fastener portions exposed to the weather shall be stainless steel or Zinc/Aluminum cap.

3. Cross Members:

- a. Manufactured from 6000-series alloy and temper-aluminum extrusions conforming to ASTM B221 and AA Aluminum Standards and Data.
- b. Receptacle in face to receive color-matched metal strips.
- c. Provide splice connectors ensuring alignment and structural continuity at end joints.

4. Color Strips: Same material and finish as roof panels; obtained from roof panel manufacturer.

5. Snow and Ice Clips:

- a. Aluminum, with rubber foot extending to and resting at surface of metal panels; minimum 3 inches (76.2 mm) wide.
  - 1) Model: SnoClip II or SnapClip II for standing seam heights 1 inch (25.4mm) to 1.5 inches (38.1 mm).
  - 2) Model: SnoClip III or SnapClip III for standing seam heights 1.75 inches (44.45 mm) to 3.25 inches (82.55 mm).

## PART 3- EXECUTION

### 3.1 EXAMINATION

Prior to beginning installation, verify:

1. Panel seaming is complete.
2. Panel attachment is sufficient to withstand loads applied by snow guard system.
3. Installation will not impeded roof drainage.

Prior to beginning installation, verify:

1. Roof attachment is sufficient to withstand loads applied by snow guard system.
2. Installation will not impede roof drainage.

### 3.2 PREPARATION

- A. Clean areas to receive attachments; remove loose and foreign matter that could interfere with installation or performance.
- B. Wipe away excess oil and debris at bracket locations.

### 3.3 INSTALLATION

- A. Install system in accordance with manufacturer's instructions and approved shop drawings.
- B. ColorGard snow retention system:
  - 1. Place clamps at maximum 32 inches (812.6 mm) on center or as required by certified calculation.
  - 2. Place clamps in straight, aligned rows using a string line.
  - 3. Place both setscrews on same side of clamp.
  - 4. Tighten setscrews to manufacturer's recommended torque. Calibrate tool to setscrew torque using calibrated dial-indicating torque wrench.
  - 5. Insert color-matched metal strips into cross members, staggering strips to cover cross-member joints.
  - 6. Attach cross members to clamps; tighten bolts to manufacturer's recommended torque.
  - 7. Install splice connectors at cross-member end joints.
  - 8. Do not cantilever cross members more than 8 inches (203.2 mm) beyond last clamp at assembly ends.
  - 9. Install SnoClips or SnapClips at spacings indicated on shop drawings.
    - a. SnoClips: slide onto cross member before securing cross member to clamps.
    - b. SnapClips: Secure clips to back side of the cross member using stainless steel #10 x ½ inch (12.7 mm) screw provided.
- 1. Place brackets at maximum 32 inches (812.6 mm) on center or as required by certified calculation.
- 2. Clean roof area to receive bracket. Remove protective seal on butyl tape.
- 3. Place brackets in straight rows along underlying substrate using a string line.
- 4. Insert color-matched metal strips into cross members.
- 5. Place brackets at spot of attachment. Fasten with screws best suited for type of attachment, and install according to the manufacturer's instructions.
- 6. Attach cross members to brackets using self drilling screws.
- 7. Install splice connectors at cross-member end joints.

8. Do not cantilever cross members more than 8 inches (203.2 mm) beyond last bracket at assembly ends.
9. Install SnoClips or SnapClips at spacings indicated on shop drawings.
  - a. SnoClips: slide onto cross member before securing cross member to clamps
  - b. SnapClips: Secure **[SnapClip II]** **[SnapClip III]** to back side of cross member using stainless steel #10 x ½ inch (12.7 mm) screw (provided).
1. Place brackets at maximum 32 inches (812.6 mm) on center or as required by certified calculation.
2. Clean roof area to receive bracket. Remove protective seal on butyl tape.
3. Place brackets in straight rows along underlying substrate using a string line. Orient the bolt hole downslope.
4. Secure the bracket directly to the rib of the panel, straddling the profile.
5. Secure the SnoBrackets by driving the provided fasteners into the pre-punched holes. All eight pre-punched holes must be used to achieve published tested strength. Drive fasteners in until they are tight and the washer is firmly seated. Do not overdrive fasteners.
6. Install the ColorGard system using Versaclips with provided M8 bolts.
7. Be sure not to cantilever more than 8 inches beyond the last bracket. Any trimmed piece of ColorGard must be attached with at least two clamps.
8. Insert color-matched metal strips into cross members.
9. Install splice connectors at cross-member end joints.
10. Install SnoClips or Snapclips at designated spacings indicated on shop drawings.
  - a. SnoClips: slide onto cross member before securing cross member to clamps.
  - b. SnapClips: Secure clips to back side of the cross member using stainless steel #10 x ½ inch (12.7 mm) screw provided.

END OF SECTION